

**PAVEMENT MARKING LEGEND**

- (A) 4" SOLID WHITE THERMOPLASTIC MARKING LINE
- (B) 6" SOLID WHITE THERMOPLASTIC MARKING LINE
- (C) 12" SOLID WHITE THERMOPLASTIC MARKING LINE
- (D) 4" DASHED WHITE THERMOPLASTIC MARKING LINE (2' STRIPE / 4' GAP)
- (E) 6" DASHED WHITE THERMOPLASTIC MARKING LINE (2' STRIPE / 4' GAP)
- (F) 4" DOUBLE SOLID YELLOW THERMOPLASTIC MARKING LINES
- (G) RIDE-A-WAY™ LIGHT GREEN COATING (3 COATS)
- (H) 6" WHITE DASHED THERMOPLASTIC MARKING LINE (2' STRIPE / 4' GAP) WITH RIDE-A-WAY™ LIGHT GREEN COATING (3 COATS) BETWEEN MARKINGS
- (J) 6" WHITE THERMOPLASTIC, ANGLED 45 DEG FROM EDGE LINE, SPACED 5'
- (K) 6" DASHED WHITE THERMOPLASTIC MARKING LINE (2' STRIPE / 2' GAP), WITH BIKE LANE GREEN MARKING
- (L) 4" DOUBLE YELLOW LINE, SOLID OUTER & DASHED INNER (10' STRIPE / 30' GAP) THERMOPLASTIC MARKING LINES
- (M) 12" SOLID YELLOW THERMOPLASTIC MARKING LINE
- (N) 4" DASHED WHITE THERMOPLASTIC MARKING LINE (3' STRIPE / 9' GAP)
- (O) 2" WHITE THERMOPLASTIC BUFFER, 4" INNER LINE, 6" OUTER LINE, & 6" CHEVRONS SPACED 10'
- (P) 24" SOLID WHITE THERMOPLASTIC MARKING LINE
- 3" x 28" FLEX POST (TYP)
- NEW SIGN ASSEMBLY
- X REMOVE SIGN

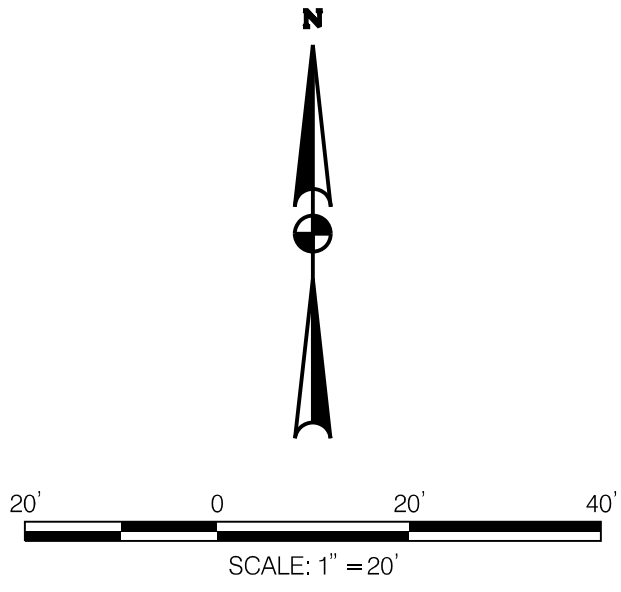

- NOTES:**
1. ALL TURNING RADIUS STRIPING SHALL BE LAID OUT AT RADIUS OF 10', TANGENT TO THE RECEIVING OR EXITING CURB LINE. FLEX POSTS SHALL THEN BE SET 1' OFF THE EDGE LINE AT EACH END, AND MIDPOINT OF THE RADIUS.
  2. ALL PROPOSED FLEX POST LOCATIONS WITHIN STRIPED BULB-OUTS SHALL BE FIELD VERIFIED BY THE ENGINEER PRIOR TO INSTALLATION.



NO.	REVISIONS	DATE
4	FINAL (100%) LAYOUT PLAN	DAG 09-27-2017
3	FINAL (90%) LAYOUT PLAN	DAG 06-09-2017
2	REVISED CONCEPTUAL (30%) LAYOUT PLAN	DAG 03-22-2017
1	CONCEPTUAL (30%) LAYOUT GRAPHIC	DAG 11-02-2016

**D.C. DEPARTMENT OF TRANSPORTATION  
POLICY, PLANNING, AND SUSTAINABILITY ADMINISTRATION  
BICYCLE AND PEDESTRIAN PROGRAM**

**I (EYE) ST SE  
(LOCATION: SOUTH CAPITOL ST SE  
TO NEW JERSEY AVE SE)**

**CYCLE TRACK CONCEPT LAYOUT – SHEET 1**

PROJECT ENG. <u>   DAG   </u>	DIVISION CHIEF
DESIGNED BY <u>   DAG   </u>	
CHECKED BY <u>   DB   </u>	
DRAWN BY <u>   DAG   </u>	
PROJECT MGR. <u>   DB   </u>	
DATE <u>   JUNE 2017   </u>	
FILE <u>   bip_l1r_s0.dgn   </u>	
SHEET <u>   1   </u> OF <u>   3   </u>	

\*SIGNS & POSTS SHALL BE RELOCATED TO LOCATIONS DIMENSIONED AS SHOWN\*

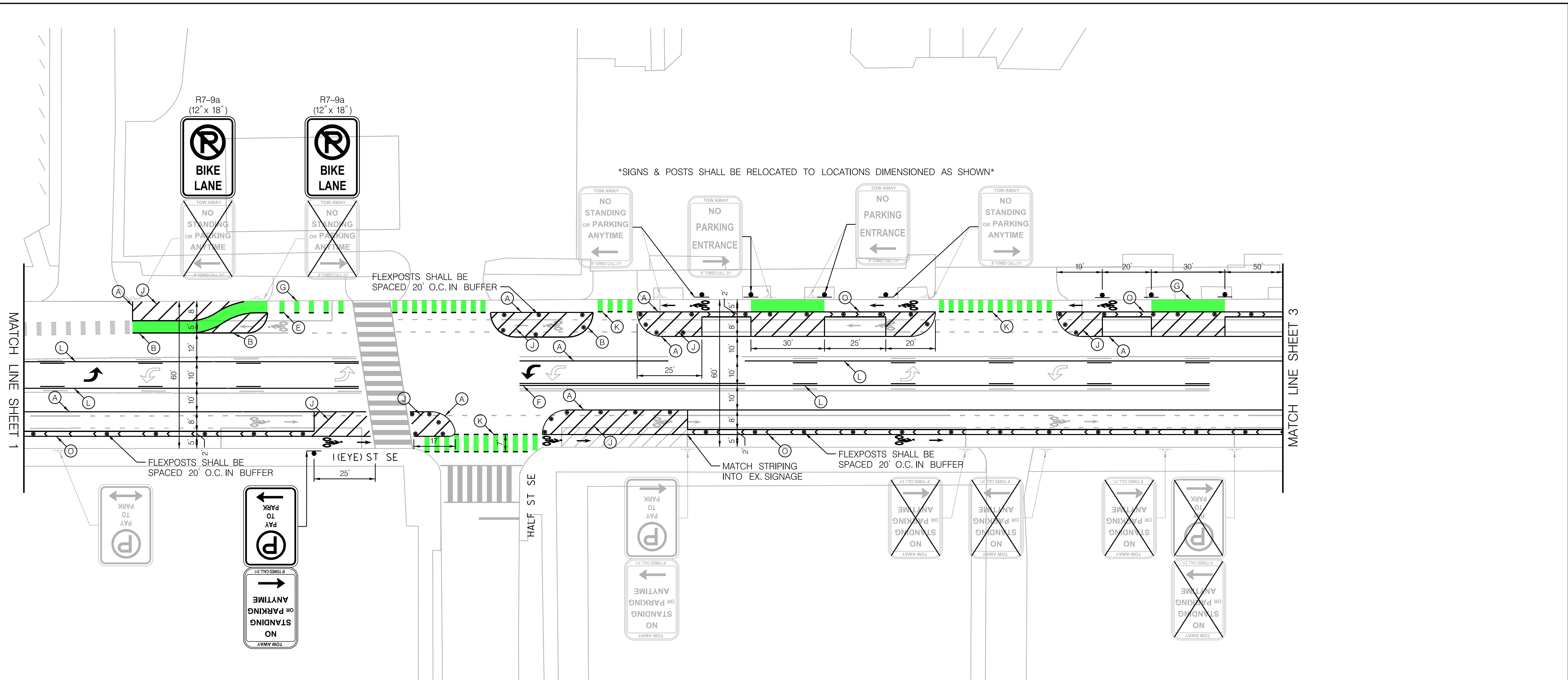

PAVEMENT MARKING LEGEND

- (A) 4" SOLID WHITE THERMOPLASTIC MARKING LINE
- (B) 6" SOLID WHITE THERMOPLASTIC MARKING LINE
- (C) 12" SOLID WHITE THERMOPLASTIC MARKING LINE
- (D) 4" DASHED WHITE THERMOPLASTIC MARKING LINE (2' STRIPE /4' GAP)
- (E) 6" DASHED WHITE THERMOPLASTIC MARKING LINE (2' STRIPE /4' GAP)
- (F) 4" DOUBLE SOLID YELLOW THERMOPLASTIC MARKING LINES
- (G) RIDE-A-WAY™ LIGHT GREEN COATING (3 COATS)
- (H) 6" WHITE DASHED THERMOPLASTIC MARKING LINE (2' STRIPE/4' GAP) WITH RIDE-A-WAY™ LIGHT GREEN COATING (3 COATS) BETWEEN MARKINGS
- (J) 6" WHITE THERMOPLASTIC, ANGLED 45 DEG FROM EDGE LINE, SPACED 5'
- (K) 6" DASHED WHITE THERMOPLASTIC MARKING LINE (2' STRIPE /2' GAP), WITH BIKE LANE GREEN MARKING
- (L) 4" DOUBLE YELLOW LINE, SOLID OUTER & DASHED INNER (10' STRIPE/30' GAP) THERMOPLASTIC MARKING LINES
- (M) 12" SOLID YELLOW THERMOPLASTIC MARKING LINE
- (N) 4" DASHED WHITE THERMOPLASTIC MARKING LINE (3' STRIPE /9' GAP)
- (O) 2' WHITE THERMOPLASTIC BUFFER, 4" INNER LINE, 6" OUTER LINE, & 6" CHEVRONS SPACED 10'
- (P) 24" SOLID WHITE THERMOPLASTIC MARKING LINE
- 3" x 28" FLEX POST (TYP)
- NEW SIGN ASSEMBLY
- X REMOVE SIGN

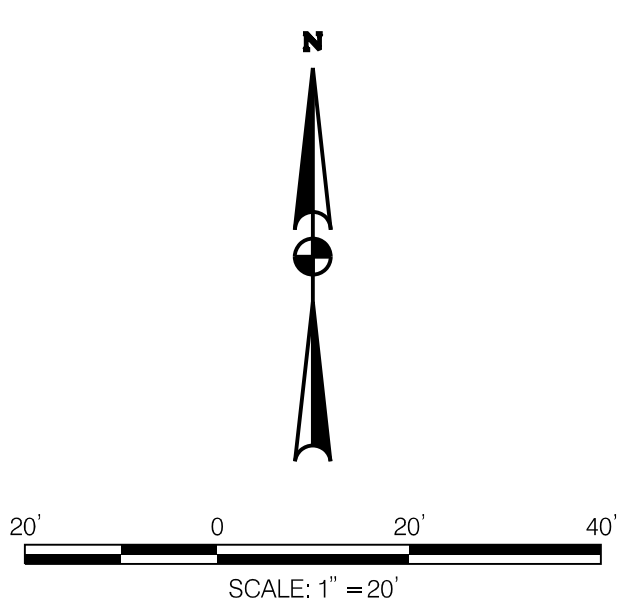

- NOTES:
- ALL TURNING RADIUS STRIPING SHALL BE LAID OUT AT RADIUS OF 10', TANGENT TO THE RECEIVING OR EXITING CURB LINE. FLEX POSTS SHALL THEN BE SET 1' OFF THE EDGE LINE AT EACH END, AND MIDPOINT OF THE RADIUS.
  - ALL PROPOSED FLEX POST LOCATIONS WITHIN STRIPED BULB-OUTS SHALL BE FIELD VERIFIED BY THE ENGINEER PRIOR TO INSTALLATION.

D.C. DEPARTMENT OF TRANSPORTATION POLICY, PLANNING, AND SUSTAINABILITY ADMINISTRATION BICYCLE AND PEDESTRIAN PROGRAM	
I (EYE) ST SE (LOCATION: SOUTH CAPITOL ST SE TO NEW JERSEY AVE SE)	PROJECT ENG. <u>   DAG   </u> DESIGNED BY <u>   DAG   </u> CHECKED BY <u>   DB   </u> DRAWN BY <u>   DAG   </u> PROJECT MGR. <u>   DB   </u>
DIVISION CHIEF	
CYCLE TRACK CONCEPT LAYOUT – SHEET 2	
DATE <u>   JUNE 2017   </u> FILE <u>   b07_L01_s03.dgn   </u> SHEET <u>   2   </u> OF <u>   3   </u>	



REVISIONS			
NO.	DESCRIPTION	DATE	BY
4	FINAL (100%) LAYOUT PLAN	09-27-2017	DAG
3	FINAL (90%) LAYOUT PLAN	06-09-2017	DAG
2	REVISED CONCEPTUAL (30%) LAYOUT PLAN	03-22-2017	DAG
1	CONCEPTUAL (30%) LAYOUT GRAPHIC	11-02-2016	DAG

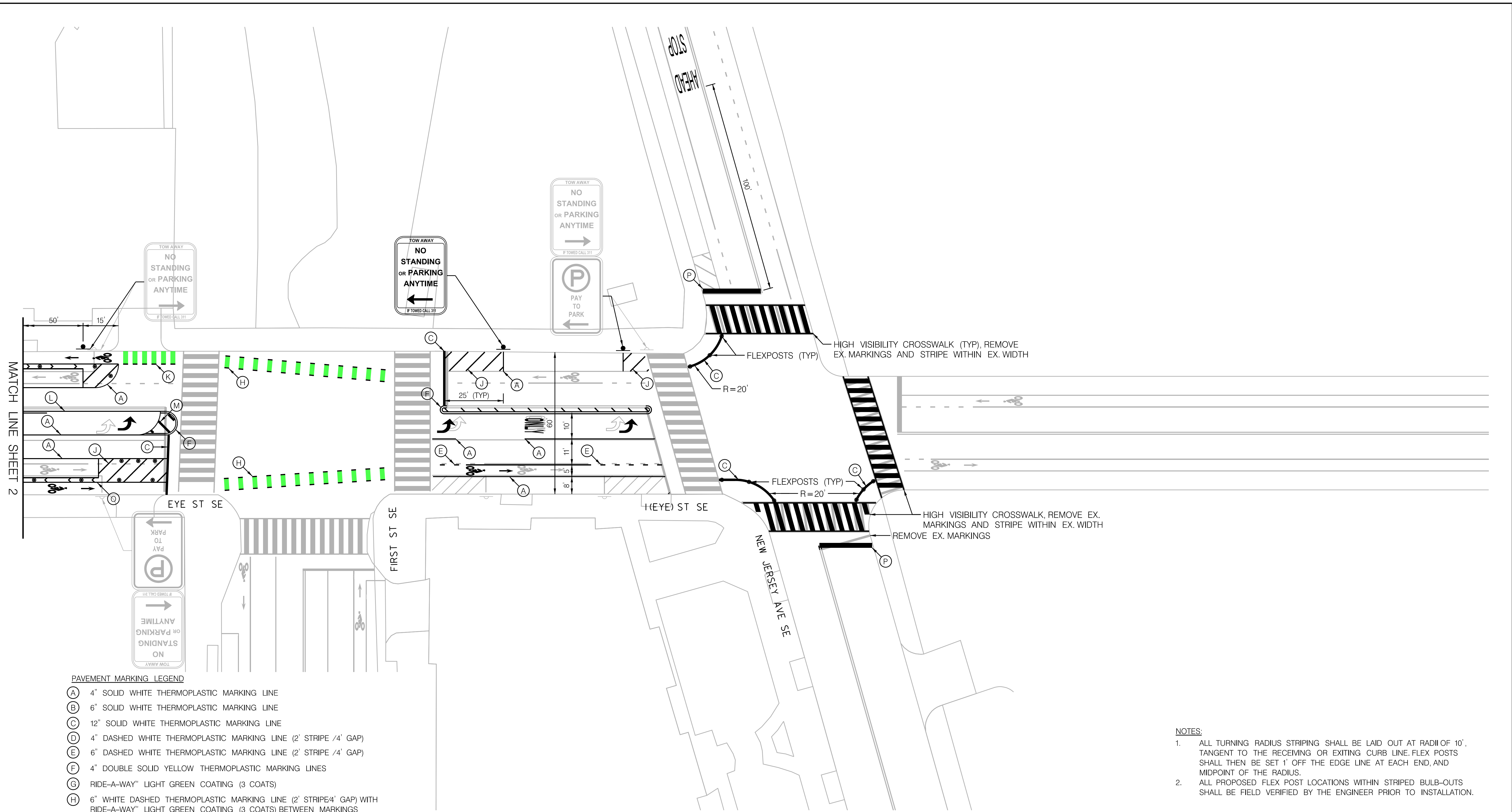

MATCH LINE SHEET 2

**PAVEMENT MARKING LEGEND**

- (A) 4" SOLID WHITE THERMOPLASTIC MARKING LINE
- (B) 6" SOLID WHITE THERMOPLASTIC MARKING LINE
- (C) 12" SOLID WHITE THERMOPLASTIC MARKING LINE
- (D) 4" DASHED WHITE THERMOPLASTIC MARKING LINE (2' STRIPE /4' GAP)
- (E) 6" DASHED WHITE THERMOPLASTIC MARKING LINE (2' STRIPE /4' GAP)
- (F) 4" DOUBLE SOLID YELLOW THERMOPLASTIC MARKING LINES
- (G) RIDE-A-WAY™ LIGHT GREEN COATING (3 COATS)
- (H) 6" WHITE DASHED THERMOPLASTIC MARKING LINE (2' STRIPE/4' GAP) WITH RIDE-A-WAY™ LIGHT GREEN COATING (3 COATS) BETWEEN MARKINGS
- (J) 6" WHITE THERMOPLASTIC, ANGLED 45 DEG FROM EDGE LINE, SPACED 5'
- (K) 6" DASHED WHITE THERMOPLASTIC MARKING LINE (2' STRIPE /2' GAP), WITH BIKE LANE GREEN MARKING
- (L) 4" DOUBLE YELLOW LINE, SOLID OUTER & DASHED INNER (10' STRIPE/30' GAP) THERMOPLASTIC MARKING LINES
- (M) 12" SOLID YELLOW THERMOPLASTIC MARKING LINE
- (N) 4" DASHED WHITE THERMOPLASTIC MARKING LINE (3' STRIPE /9' GAP)
- (O) 2' WHITE THERMOPLASTIC BUFFER, 4" INNER LINE, 6" OUTER LINE, & 6" CHEVRONS SPACED 10'
- (P) 24" SOLID WHITE THERMOPLASTIC MARKING LINE
- 3" x 28" FLEX POST (TYP)
- NEW SIGN ASSEMBLY
- X REMOVE SIGN

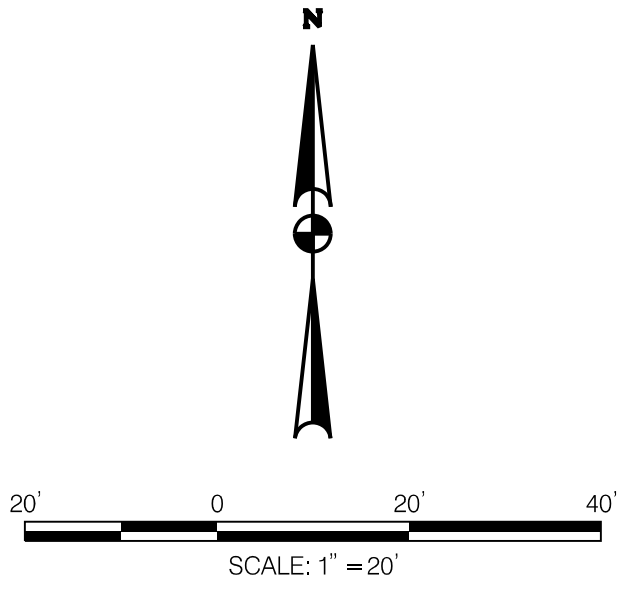

- NOTES:**
1. ALL TURNING RADIUS STRIPING SHALL BE LAID OUT AT RADIUS OF 10', TANGENT TO THE RECEIVING OR EXITING CURB LINE. FLEX POSTS SHALL THEN BE SET 1' OFF THE EDGE LINE AT EACH END, AND MIDPOINT OF THE RADIUS.
  2. ALL PROPOSED FLEX POST LOCATIONS WITHIN STRIPED BULB-OUTS SHALL BE FIELD VERIFIED BY THE ENGINEER PRIOR TO INSTALLATION.



NO.	REVISIONS	DATE
4	FINAL (100%) LAYOUT PLAN	DAG 09-27-2017
3	FINAL (90%) LAYOUT PLAN	DAG 06-09-2017
2	REVISED CONCEPTUAL (30%) LAYOUT PLAN	DAG 03-22-2017
1	CONCEPTUAL (30%) LAYOUT GRAPHIC	DAG 11-02-2016

<b>D.C. DEPARTMENT OF TRANSPORTATION</b> POLICY, PLANNING, AND SUSTAINABILITY ADMINISTRATION BICYCLE AND PEDESTRIAN PROGRAM	
<b>I (EYE) ST SE</b> (LOCATION: SOUTH CAPITOL ST SE TO NEW JERSEY AVE SE)	PROJECT ENG. <u>   DAG   </u> DESIGNED BY <u>   DAG   </u> CHECKED BY <u>   DB   </u> DRAWN BY <u>   DAG   </u> PROJECT MGR. <u>   DB   </u>
<b>CYCLE TRACK CONCEPT LAYOUT – SHEET 3</b>	
DATE <u>   JUNE 2017   </u> FILE <u>   b07_L01_s03.dgn   </u> SHEET <u>   3   </u> OF <u>   3   </u>	